

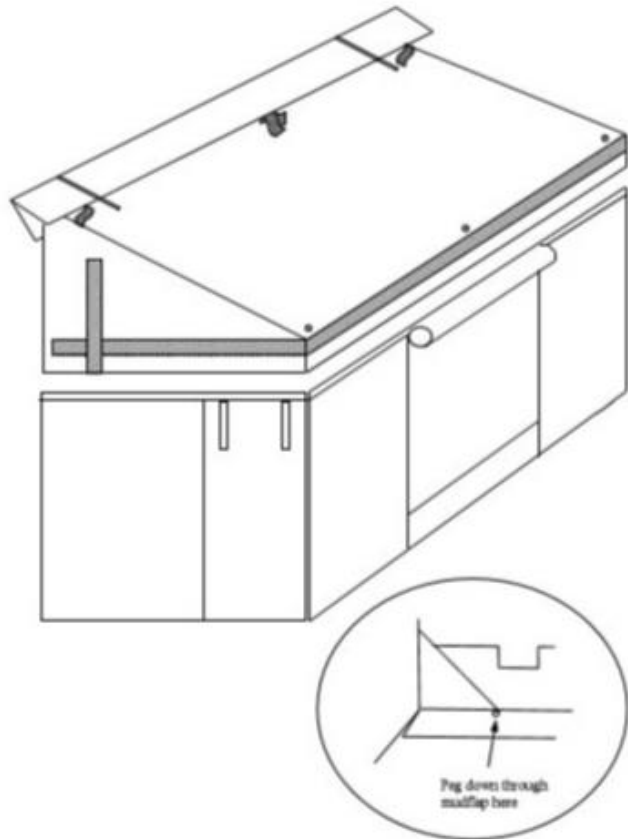

Alpine Annexes

ABN 22 627 499 245 ACN 627 499 245
Fac 30/513 Maroondah Hwy, Ringwood, 3134
Ph: (03) 9870 6102
sales@alpineannexes.com.au
www.alpineannexes.com.au

Bag Awning Walls Set Up



Erection Instructions (Spring Loaded Poles)

Note: Bag Awnings are normally used on wind-up type campers where the initial opening and unrolling of the awning can be done at an easy height before winding camper up. For Bag Awnings fitted to other vans (often on rear door vans) a small step ladder or step may be an advantage)

1. BAG AWNING Unzip bag, undo centre Velcro strap which holds awning inside bag and allow awning to unroll. (If on wind up camper now you can finish erecting the camper)
2. Unpack poles from bag. You have three types of poles.

1. 3 x 7'6 adjustable uprights which have plastic cap on the bottom,
2. have a threaded spigot with

wing nut at the top plus a side hole approx. 50mm from top these are the corner poles and

one has a 'C' clamp this is the centre pole (thumbscrew allow height to be adjusted)

(ii) spring loaded poles which hold awning out from van, plastic cap on end

near van, end poles have a spigot at the other end and the centre one has a 'C' clamp—all with

inbuilt spring to offer constant tension.

(iii) long double spreader which stays inside pocket of awning

3. Place an upright pole into end of long spreader and then through a corner eyelet of the awning and adjust height until bottom of roof wedge is roughly horizontal. Screw wing nut onto threaded spigot but only a few turns are needed to stop awning blowing off during erection in windy conditions.

4. Cap end of spring-loaded pole now slips into Velcro loop at van end of roof and spigot goes into hole at

top of upright pole (you need to compress spring to do this) The van is protected from end of spring-loaded pole by the lower part of unzipped bag. (Note: once you have Velcro around the pole you should

be able to slide pole out when dismantling so that Velcro is already in a loop for future erection)

5. Repeat 3 and 4 with other corner pole and then with centre pole (centre upright and centre spring loaded roof pole both clip onto midpoint of double spreader). [Fig 2] Corner guy ropes are supplied for use if awning is erected without walls or when windy conditions are imminent. Attach guy ropes and peg down.

now if needed. (Note Family Bag Awnings have 2 extra spring-loaded poles)

6. BAG AWNING WALLS Press stud draught skirt under van. Peg down to ground. [Fig 3]

7. Velcro top of end walls to ends of awning. Lift bottom of walls up and slide down into track on van. Velcro long wall to awning and zip walls together in corners. Peg walls down making sure walls are square.

to each other. (4 pegs will go through bottom of draught skirt, no need to worry, they will go into these

same holes on every occasion)

8. Readjust upright poles to ensure that wall heights are reasonably tight.

9. In most cases cover flaps on camper surround will now Velcro onto wedge of awning and side of end

walls to help further seal from weather.

10. Reverse instructions to dismantle. If unit is wet when dismantling, make sure to dry and air out within 24 hours.

