



## Alpine Annexes

ABN 22 627 499 245 ACN 627 499 245

Fac 30/513 Maroondah Hwy, Ringwood, 3134

Ph: (03) 9870 6102

[sales@alpineannexes.com.au](mailto:sales@alpineannexes.com.au)

[www.alpineannexes.com.au](http://www.alpineannexes.com.au)

# Bag Awning Walls Set Up

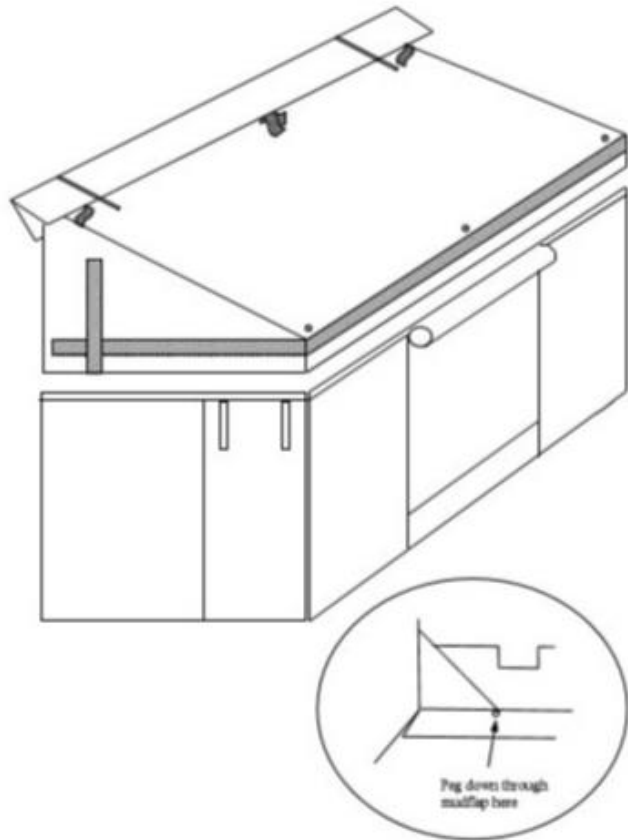

## Bag Awning and Walls Set Up Instructions

**Note:** Bag Awnings are normally used on wind-up type campers where the initial opening and unrolling of the awning can be done at an easy height before winding camper up. For Bag Awnings fitted to other vans (often on rear door vans) a small step ladder or step may be an advantage)

1. Start by, (while the van is still down) unzipping the bag, undo the Velcro strap which holds the awning inside the bag and allow the awning to unroll. There will be a long spreader pole already in the length of the Bag Awning (If this is on wind up camper you can now finish erecting the camper)

2. Unpack poles from bag. You have three types of poles.

- 1) 3 x 9' **Adjustable Upright Poles** which have plastic cap on the bottom, and a spike on the top.
- 2) 2 x **Roof Rails with an eyelet** on one end and a hook on the other end (these go on either end of the awning)
- 3) 2 x **Roof Rafters with a 'C' Clip** on one end and a hook on the other end (these go in the middle of the awning)

3. Using 1x **Adjustable Upright Pole**, place spike into the centre hole in the bag awning pole

**NB.** A helpful tip is to pull the foot of the pole toward the van, this will help hold the awning out from the van while putting in the other poles.

**4.** Now take 2x **Roof Rafters with a 'C' Clip**, hook them into the bracket on the van and push the 'C' Clip onto the pole in the bag awning.

**5.** Using 1x **Adjustable Upright Pole** and 1x **Roof Rails with an eyelet**, Hook the Roof Rail into the bracket on the van, thread the spike of the upright pole through the eyelet at the end of the roof rail, then through the eyelet of the bag awning pole and the corner eyelet in the awning roof, adjust height until the bottom of roof wedge is roughly horizontal. Attach the rope and peg into place, repeat at the other end.

**6.** Press stud draught skirt to the bottom of the van. Peg down to the ground.

**7.** Velcro top of the end walls to the ends of the awning. Lift the bottom the of walls up and slide down into track on the van. Velcro the long wall to awning and zip walls together in the corners. Peg walls down making sure walls are square to each other.

**8.** Readjust upright poles to ensure that wall heights are reasonably tight.

**9.** In most cases cover flaps on camper surround will now Velcro onto wedge of awning and side of end walls to help further seal from weather.

**10.** Reverse instructions to dismantle. If unit is wet when dismantling, make sure to dry and air out within 24 hours.